

# After Market Sales/Services

Innovative Enhancements to Increase Productivity and Reliability



## SLS1000 Enhancements

### Web Width Reduction Kits Available!

#### SLS1000A Upgrade Kit - SL12-333

Utilize 42" web width products as jackets. Upgrade kit includes: new moveable wall with bearings and fittings, threaded sucker port, new 'L' gripper on right hand side, pocket bumpers and sucker cups.

#### SLS1000 Upgrade Kit - SL12-326

Utilize 42" web width products as jackets. Upgrade kit includes: new moveable wall with bearings and fittings, relocation bracket, new 'L' gripper on right hand side, pocket bumpers and sucker cups.

New Sucker Position

New Longer Gripper

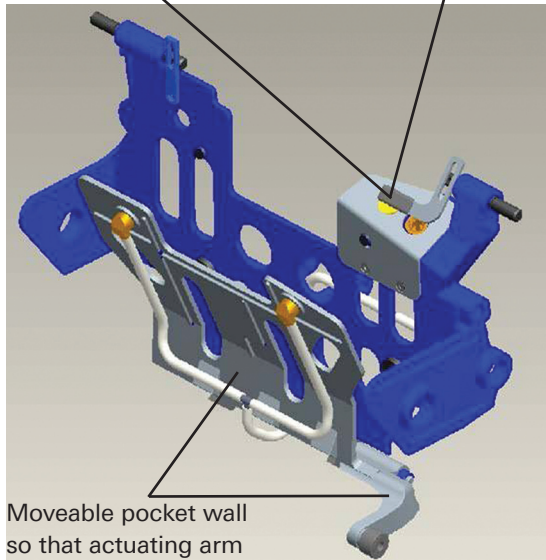

Moveable pocket wall so that actuating arm is not weakened.



#### Safety Guarding

Keep your employees protected by placing safe guarding for your SLS1000 with Lexan covers. Also, keeps your mailroom OSHA compliant.

#### SLS1000/SLS2000 Conveyor Gripper Exchange Program - TBD per site

Remanufactured Gripper with exchange of used gripper.



After Market Sales and Services Contact Information

#### General Information:

Phone: 610.266.7069  
Fax: 610.231.3994  
Email: [aftermarket@mullermartinims.com](mailto:aftermarket@mullermartinims.com)

#### After Market Sales/Services Manager

Dan Cropley  
Phone: 610.266.7069  
Fax: 610.231.3994  
Email: [dan.cropley@mullermartinims.com](mailto:dan.cropley@mullermartinims.com)

**Conveyor Chain Life/Tension  
- 7702.8368**

A new link design and increased ball joint sizes allow you to endure a higher load and extend the chains life.

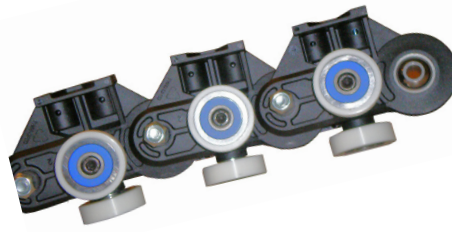
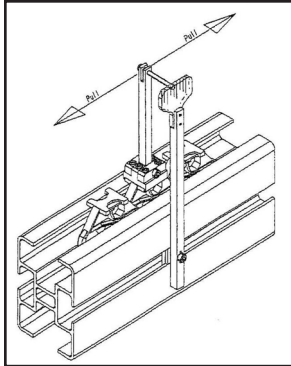

**NewsGrip II R Chain -  
7582.1423.1**

New link design with an increased ball joint size to endure higher loads and extend chain life.

**SLS1000 Remanufactured/  
Exchange of Standard Hopper  
Program - 6018-00004CS**

Complete Mechanical Rebuild of an SLS1000 Hopper with exchange of used hopper.